

1 Features

- Tough aluminum 6061-T6 enclosure
- Waterproof to 6ft
- Compact size 4.8"x2.6"x1.5"
- Weighs 12.5oz including X6-2 or X250-2
- 1500mAH lithium-polymer rechargeable battery to extend operating life
- External watertight button to initiate data recording
- Watertight mini-USB connector
- 2 status indicators visible on top
- Gold color anodized to resist corrosion
- Externally operated, no need to open the enclosure

2 Applications

The HD enclosure accommodates the X6-2 or X250-2 USB self-recording accelerometers offered by GCDC.

3 Description

The HD heavy duty enclosure offers a rugged, weatherproof solution to environmentally demanding applications using the USB accelerometers offered by GCDC. The tough aluminum enclosure protects the X6-2 or X250-2 devices from damage and provides a convenient 4-point mount.



Figure 1: HD Aluminum Enclosure

3.1 Electrical

3.1.1 Status LEDs and on/off Button

The two status LEDs indicate system operation of the X6-2 or X250-2 devices (see Figure 2). Press the on/off button once to turn the system on. Press and hold the on/off button for approximately 3 seconds to turn the system off. The “Data” LED indicates when data is written to the microSD card or lights when the battery is charging. The “Status” LED blinks when the device is operating. Reference the X6-2 or X250-2 specifications for detailed operating procedures.

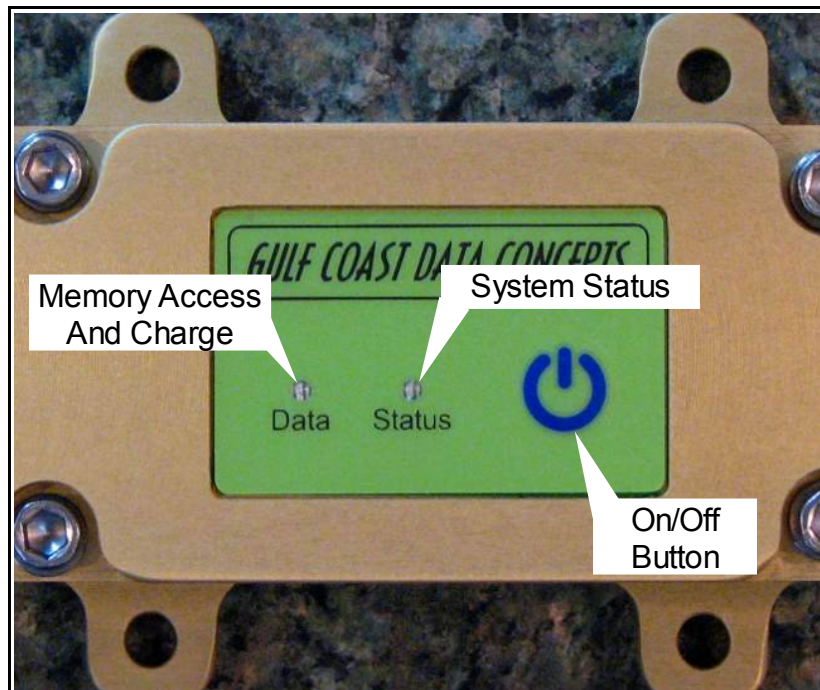

Figure 2: LED Functions

3.1.2 USB Connector

The X6-2 and X250-2 are accessible via the watertight mini-B USB connector. Remove the protective cap and connect the provided mini-B to type-A adapter cable. Plug the type-A male connector of the adapter cable into a personal computer and the data and configuration files will be accessible via the mass storage device interface. The internal 1500mAH lithium-polymer battery will begin to recharge when the USB cable is connected to a computer. A completely discharged battery may take up to 20 hours to recharge.

3.1.3 Sensor Orientation

Sensor orientation depends on the accelerometer data logging device mounted inside the HD enclosure. The two options are illustrated in Figure 3.

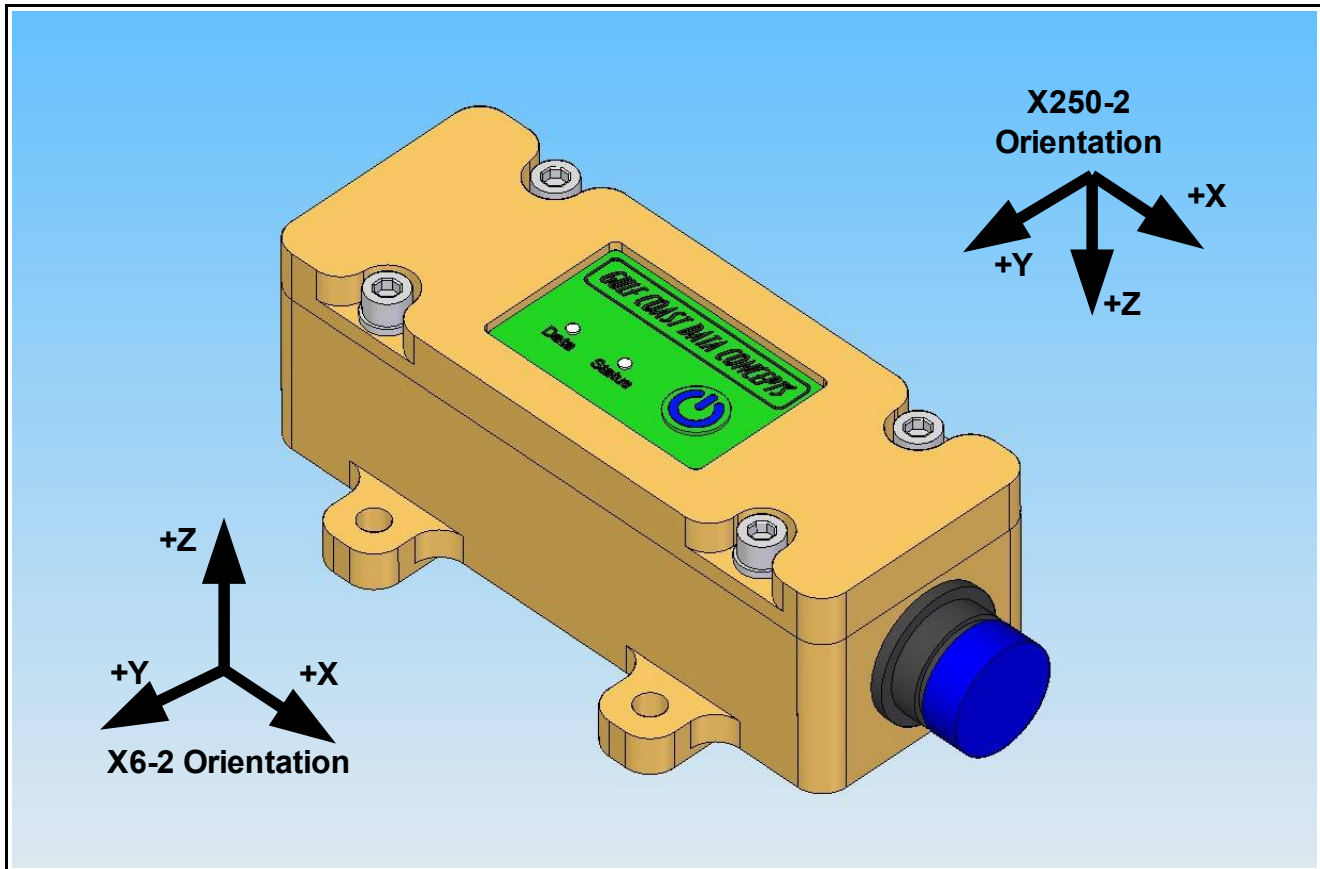

Figure 3: Sensor Orientation

3.2 Mechanical

The HD enclosure measures 4.840" (119mm) in length, 2.625" (64mm) in width and 1.5" (37mm) in height. The HD assembly including an X6-2 or X250-2 device weighs 12.5oz (355g). The enclosure accommodates #10 machine screws at four 0.201" diameter mounting points, located on 2.125" centers.

3.2.1 Dimensions

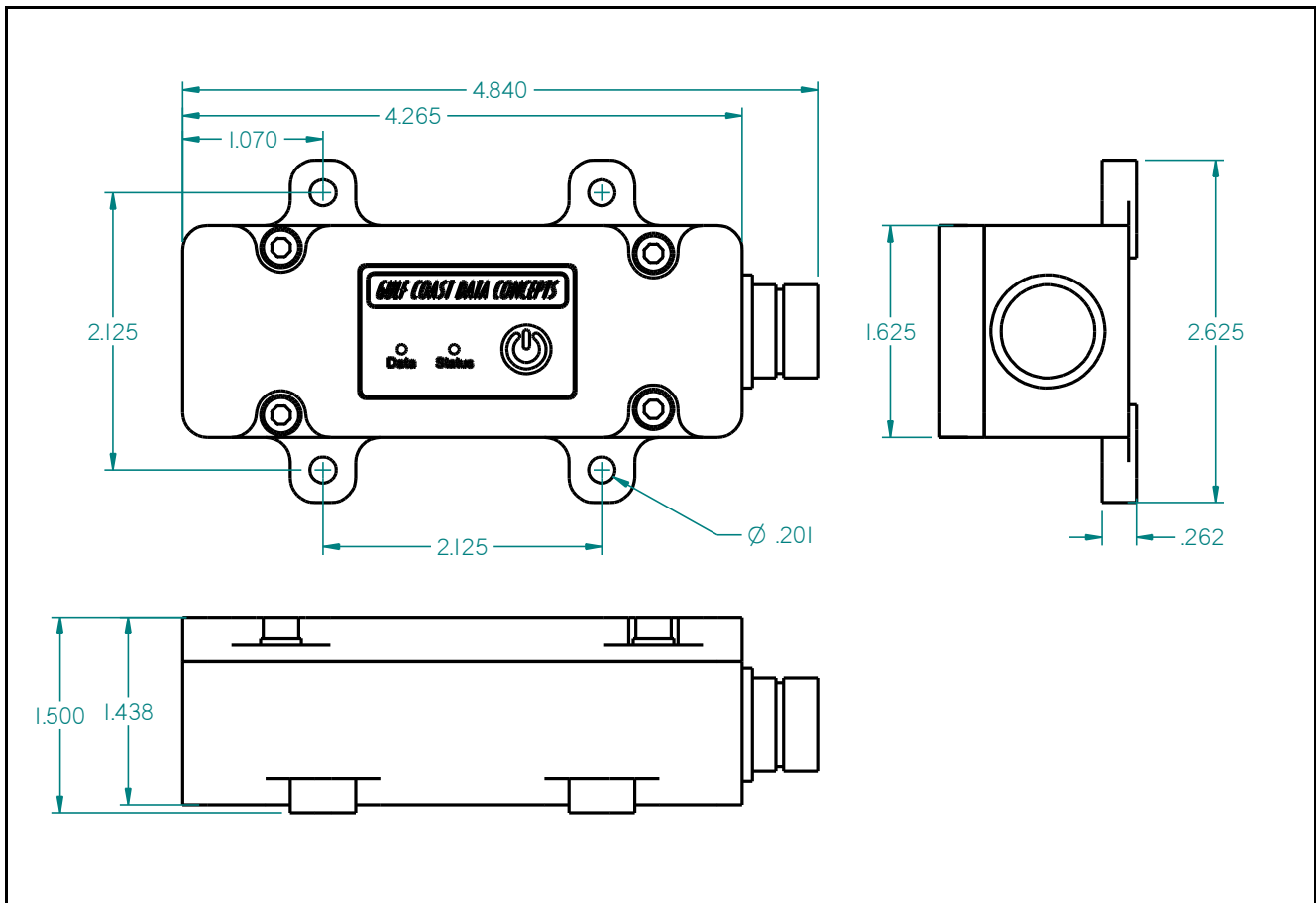

Figure 4: Dimensions of the HD Enclosure